

L200-TPP-180D

Pink

5mm, Flanged Cylindrical, 8.6mm Height
180° viewing angle

DWG BY:
LL / GP
02-14-07

CHK BY:
PL
02-14-07

QA:
—
— — — —

MFG:
—
— — — —

REVISION LTR: -
02-14-07

Features:

- ? High intensity
- ? 5mm diameter package
- ? Tinned leads
- ? Pb-free

Package Dimensions:

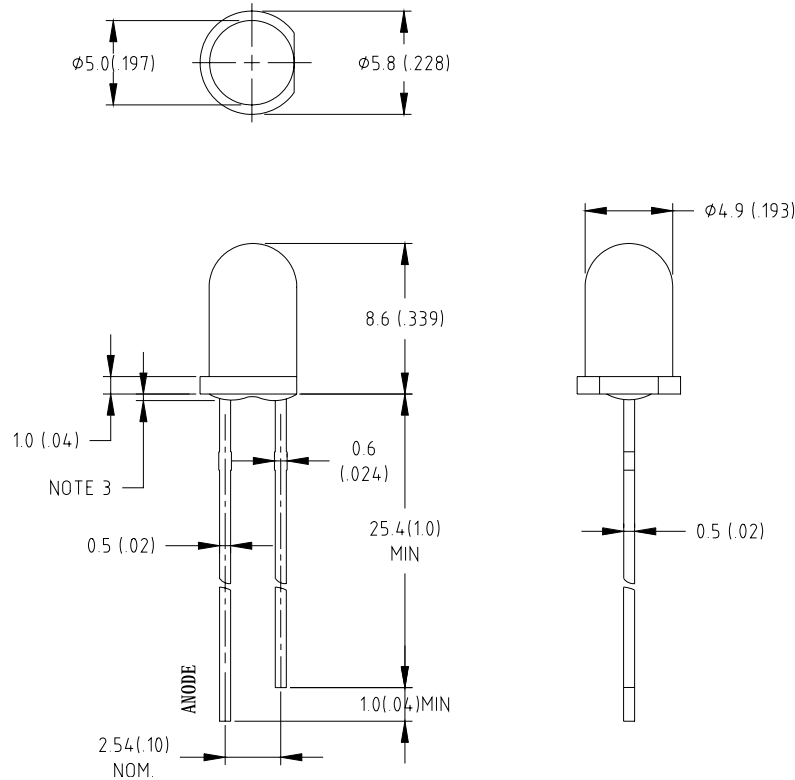

Part No.	Chip Material	Lens Color	Emission Color
L200-TPP-180D	InGaN	Pink Diffused	Pink

Notes:

1. All dimensions are in millimeters (inches).
2. Tolerance is ± 0.25 mm (.010") unless otherwise noted.
3. Protruded resin under flange is 1.0mm (.04") max.
4. Lead spacing is measured where the leads emerge from the package.
5. Specifications are subject to change without notice.
6. Precautions for ESD:
 Static electricity and surge can damages the LED. It is recommended to use a wrist band or anti-electrostatic glove when handling the LED. All devices, equipment and machinery must be properly grounded.

Absolute Maximum Ratings at Ta=25°C

Parameter	MAX.	Unit
Power Dissipation	80	mW
Peak Forward Current (1/10 Duty Cycle, 0.1ms Pulse Width)	100	mA
Continuous Forward Current	20	mA
Derating Linear From 50°C	0.4	mA/°C
Reverse Voltage	5	V
Electrostatic Discharge (ESD)	150	V
Operating Temperature Range	-30°C to +80°C	
Storage Temperature Range	-40°C to +100°C	
Lead Soldering Temperature [4mm(.157") From Body]	260°C for 5 Seconds	

Electrical Optical Characteristics at Ta=25°C

Parameter	Symbol	Min.	Typ.	Max.	Unit	Test Condition
Luminous Intensity	I _v	40	80	---	mcd	I _F =20mA (Note 1)
Viewing Angle	2θ _{1/2}	170	180	---	Deg	(Note 2)
x,y coordinates (CIE 1931 2)	x	---	0.53	---	---	I _F =20mA (Note 3)
	y	---	0.24	---	---	I _F =20mA (Note 3)
Forward Voltage	V _F	---	3.3	4.0	V	I _F =20mA
Reverse Current	I _R	---	---	50	μA	V _R =5V

Notes:

- Luminous intensity is measured with a light sensor and filter combination that approximates the CIE eye-response curve.
- θ_{1/2} is the off-axis angle at which the luminous intensity is half the axial luminous intensity.
- The x and y parameters correspond to the CIE 1931 Chromaticity Diagram. X, Y, and Z are the tristimulus values calculated using the spectral distribution data.
- Forward voltage measurement allowance is ±0.1V
- Luminous Intensity Measurement Allowance is ±10%

**Typical Electrical / Optical Characteristics Curves
 (25°C Ambient Temperature Unless Otherwise Noted)**

